

The QUICK LIFT L520E is a lifting tool designed for the repair of passenger vehicles. It allows vehicles to be lifted safely. The maximum load of the QUICK LIFT is 2500 Kg.

SAFE
EN 1493

LIGHT, COMPACT & MOBILE

- With a weight of 42 kg the QUICK LIFT is simple to handle and makes it very easy to set up.
- It has a small footprint and is easy to move thanks to its wheels.
- Allows for quick tire or brake service and unobstructed access to the chassis.
- It folds down to only 88 mm to free up as much space as possible.

CAPACITY & COMPATIBILITY

- The QUICK LIFT can lift up to 2.5 tons.
- It is compatible with most passenger and commercial vehicles.

OPTIMIZED HYDRAULIC SYSTEMS

- The hydraulic power pack is portable and silent (220 V ~1). Equipped with a valve with balancer for synchronized lifting.
- Push-button remote control with 4 m cord for easy handling.
- Sealed connections prevent fluids from spilling onto the floor.

SAFE & RUGGED

- Dual-position automatic locks engage automatically when lifting.
- The QUICKLIFT is manufactured with a welded structure in very resistant steel.



Supplied with:

- 2 hydraulic ramps
- hydraulic assembly
- 8 skates (100x120x50 mm)



SUV option (142 mm)
ref. 065017

Hydraulic oil - 5 l
ref. 062160

Dimensions:

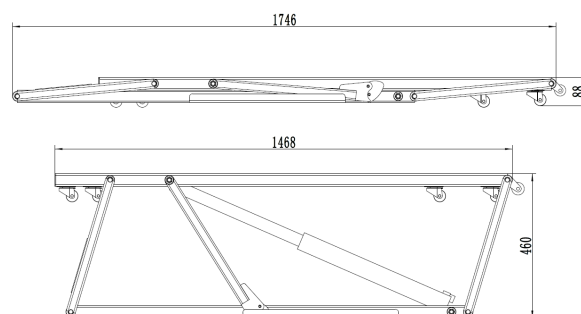

2,5 T



30 - 45 s.



220 V in



0,75 kW



< 70 dA



x2 : 37 x 10,5 x 181 cm
+
41 x 43 x 53 cm



125 kg